

Your fight is our fight.

With the current unprecedented circumstances of COVID-19, the health and safety of your team and your customers entering your premises has never been more important. We are here to help you.

HAND SANITISER UNIT FOR RETAIL AND HOSPITALITY

370x200mm | 600x600mm | 1200x400mm

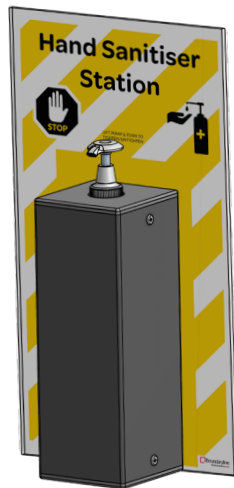

HAND SANITISER UNITS - RETAIL & HOSPITALITY

FEATURES

- Robust design to handle constant use
- Can be fixed to wall (heavy-duty double sided tape included)
- Printed backing board to draw customers attention
- Allows 400-500 uses between refills
- Includes re-fillable cylinder for any liquid hand sanitiser

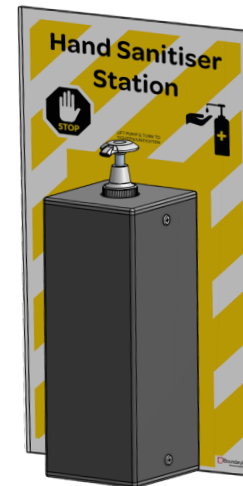
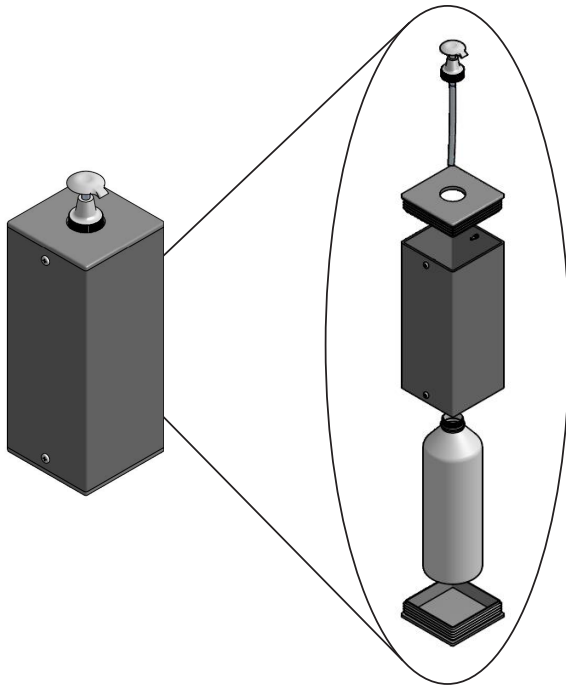

HAND SANITISER UNITS - MODEL OPTIONS

• Eco Unit

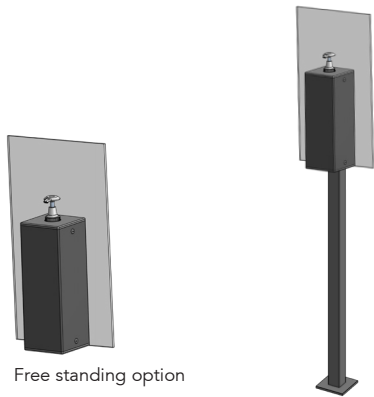

Dimensions: 370mm x 200mm

Code	Model	Price
XES1000-BK	Screw Fix	\$143.89
XEB1000-BK	Bolt-down (includes 1x flanged post&cap)	\$220.50

• Single Unit

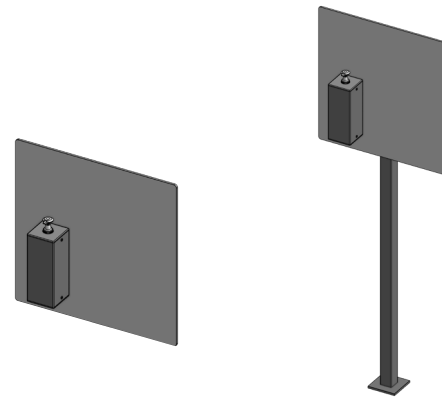

Dimensions: 600mm x 600mm

Code	Model	Price
XHS1000-BK	Screw Fix	\$166.11
XHB1000-BK	Bolt-down (includes 1x flanged post&cap)	\$230.43

• Double Unit

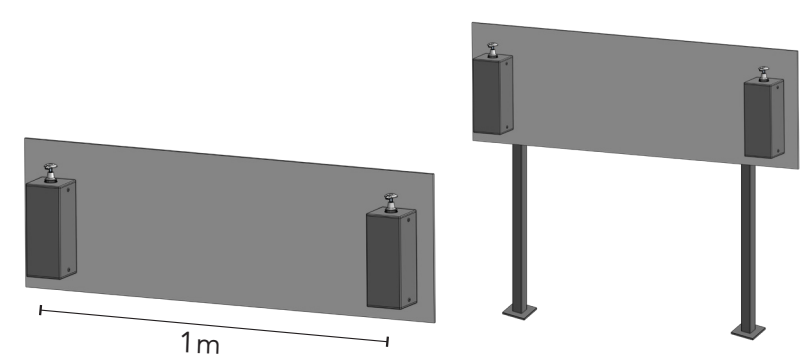

Dimensions: 1200mm x 400mm

Code	Model	Price
XHS2000-BK	Screw Fix	\$298.89
XHB2000-BK	Bolt-down (includes 2x flanged post&cap)	\$427.53

• All prices + GST and exclude delivery. Add \$64.00 +GST per order for packaging and deliver to any main centre of New Zealand to commercial premises with forklift unloading capability.

• **NOTE: Hand Sanitiser Liquid not included**

APPLICATIONS

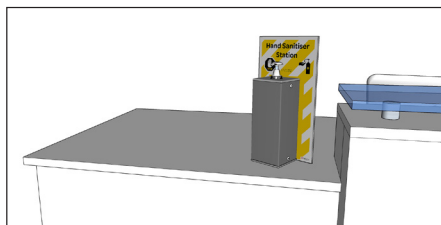

Counter Tops (**Eco Unit only**)



Cafe Counter



Retail Store

ABOUT US

The team at Boundaryline are united in the national fight against Covid-19 and helping protect our fellow New Zealanders.

We have the experience, product and ability to provide solutions for your needs quickly and into every corner of the country.

Need something else in your fight against Covid-19?
Call our friendly team to discuss how we can help you.

CONTACT US

Phone: 0800 003 006

Enquiries: enquiries@boundaryline.co.nz

Orders: orders@boundaryline.co.nz

